

TYNDP 2026

Scenario Building

Joint ENTSO-E - ENTSGO webinar

6 March 2025

10:00 – 12:00 CET

TYNDP 2026 Scenarios Process Update Webinar

TYNDP 2026

Scenario Building

Introduction

10 minutes

Privacy disclaimer

This is a public webinar. Please be aware that:

- the workshop is going to be recorded
- the video recording and the presentations will be made available online to allow for a dissemination of the webinar content to a wider public

Introduction

Scenarios built in line with policy targets, taking into account the latest available data at the time. They comply with ACERs framework guidelines.

Central scenario NT+ fully relies on NECPs, translating member states policies into a consistent EU-wide picture.

Extensive stakeholder engagement and enhanced transparency of the process and tools used are supporting the robustness of the central scenario.

The 2026 scenarios will provide a sound basis to develop an infrastructure that is fit for purpose to meet the policies outlined in the NECPs

AGENDA

No	Subject	TIME	WHO
01.	Introduction	10:00 - 10:10 10 min	Alan Croes (ENTSO-E and TenneT)
02.	TYNDP 2026 Scenarios Framework	10:10 - 10:25 15 min	Alexander Kaettlitz (ENTSOG)
03.	TYNDP 2026 Scenarios Timeline	10:25 - 10:35 10 min	Nalan Buyuk (ENTSO-E)
04.	Q&A Session	10:35 - 10:50 15 min	Moderated by Léa Dehaut (ENTSO-E)
05.	Innovation Roadmap	10:50 - 11:10 20 min	Laura López (ENTSO-E and Red Eléctrica)
06.	Collaboration for the 2026 TYNDP cycles	11:10 - 11:20 10 min	Andrzej Ceglarz and Elisabeth Cremona, Stakeholder Reference Group convenors
07.	Q&A Session	11:20 – 11:50 30 min	Moderated by Nalan Buyuk (ENTSO-E)
08.	Next Steps & Closing	11:50 – 12:00 10 min	Kacper Zeromski (ENTSOG)

Get involved in the Workshop!



Throughout the workshop you can ask your own questions, like other participants' questions, and leave comments.

What to do:

1. Go to **slido.com**
2. Enter the event code **#3087 824**
3. Enter your name and surname (NB: anonymous questions will not be answered)
4. Start asking your questions
5. Like other participants' questions - the most liked ones will rank higher on the list

TYNDP 2026

Scenario Building

TYNDP 2026 Scenarios Framework

15 minutes

TYNDP 2026 Scenarios Framework

Central scenario (National Trends+) reflecting latest updated NECPs, national and EU policies

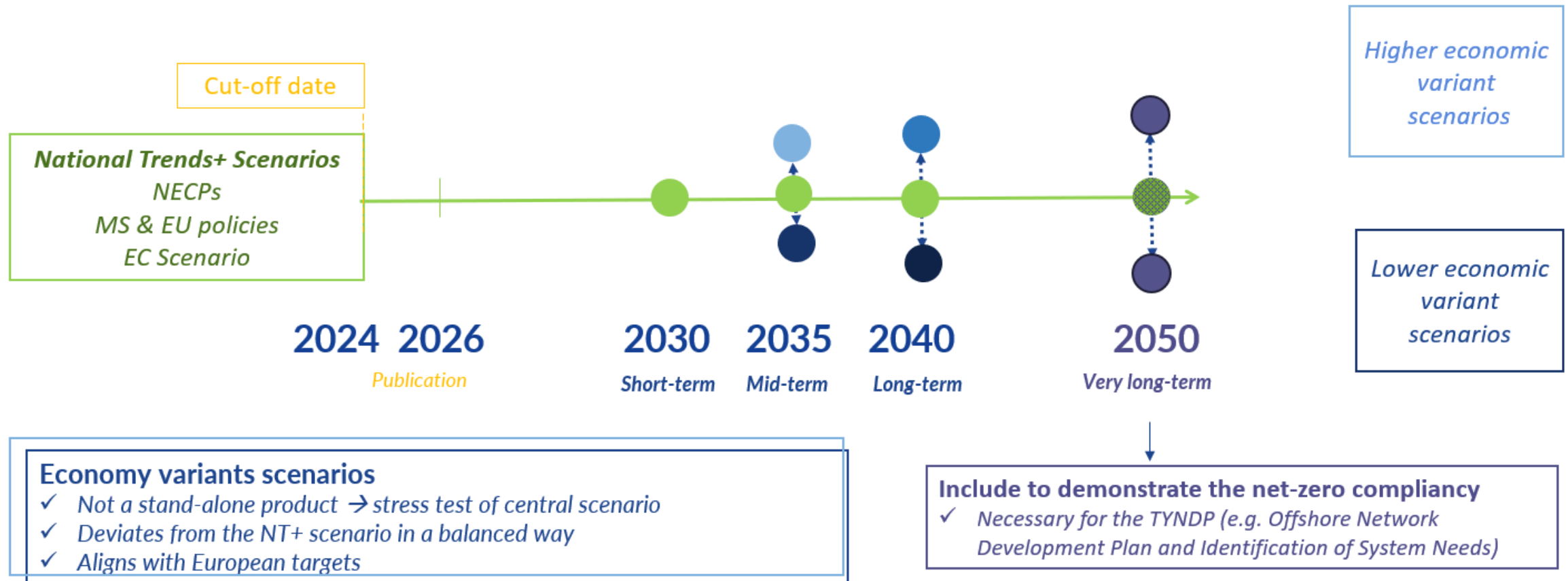

Main principles on the variants

1. Limited differentiation from the central view

- ❖ Aim is not exploring extreme economic conditions; more 'realistic' deviations from the central scenario

2. Selection of least and most pragmatic parameters

- ❖ Purpose is not developing a full storyline, rather a sensitivity
- ❖ To improve efficiency by avoiding complexity

3. Balanced way of differentiation

- ❖ Differentiation on each selected parameters will be balanced; e.g. if x% increase in one variant, x% decrease will be implemented in the other variant

4. Both variants are aligned with targets

- ❖ Variants will be developed for 2035-, 2040- and 2050-time horizons.
- ❖ The aim is to have a reasonable pathway from 2030 union targets and reach net-zero by 2050

High-level definition of the economic variants



Higher economic growth

- ✓ Higher GDP (higher than NECPs)
- ✓ Higher sectorial activity
- ✓ More purchasing appetite / more willingness to spend
- ✓ More focus on innovation & risky investments
- ✓ More focus on sustainability, long-term view for investment/purchasing decision

Lower economic growth

- ✓ Lower GDP (lower than NECPs, close to 0 growth)
- ✓ Moderate/less sectorial activity
- ✓ Moderate/Less purchasing / spending possibilities
- ✓ Less focus on innovation & more business as usual
- ✓ More focus on cost and affordability, short-term view for investment/purchasing decision

Differentiation on demand parameters

Sectors

Household & Buildings

Transport

Industry

Agriculture

What is changing compared to the central scenario?

Activity

Efficiency

Technology mix

Building blocks for differentiation of the variants - supply

Overall approach

- Based on the high-level definition of the economic variants, each building block is assessed regarding the possible variation
- For some building blocks, variation in both directions (higher or lower) is imaginable, based on the respective reasoning

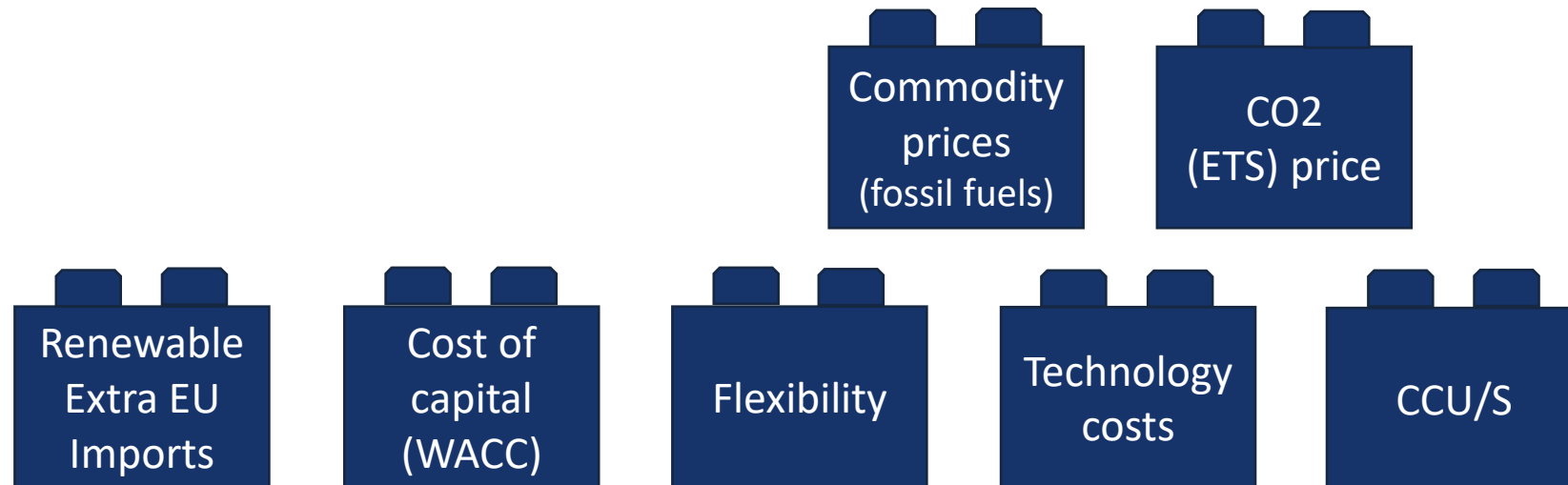

TYNDP 2026

Scenario Building

TYNDP 2026 Scenarios Timeline

10 minutes

TYNDP 2026 Scenarios Timeline

Cut-off date 24 December 2024

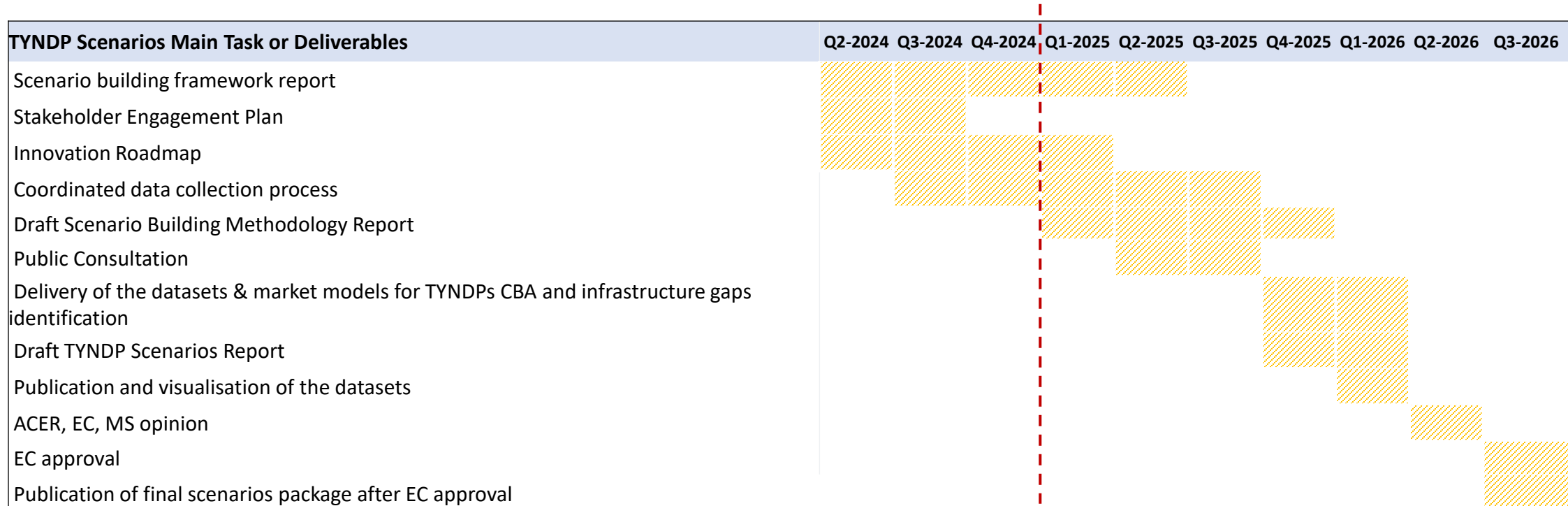

The detailed timeline is available on the scenario's dedicated website 2026.entsoe-tyndp-scenarios.eu

The stakeholder engagement plan and Innovation Roadmap are publicly available.

The input parameters & methodologies are planned to be published for public consultation in late May 2025.

TYNDP 2026

Scenario Building

Q&A

Participants can join at [slido.com](https://www.slido.com) with code #3087824
15 minutes



TYNDP 2026

Scenario Building

TYNDP 2026 Innovation Roadmap

20 minutes

Innovation Roadmap

Roadmap based on feedback and guidelines from:

- Article 12 of Regulation 2022/869 (TEN-E Regulation)
- ACER Framework Guideline
- European Scientific Advisory Board on Climate Change
- SRG and TSO Recommendations for TYNDP 2024

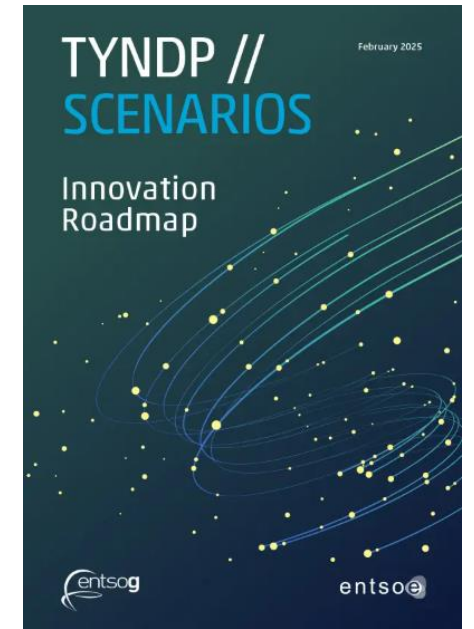

Published on 25 February 2025: https://2026.entsoe-tyndp-scenarios.eu/wp-content/uploads/2025/02/entsoe_Scenarios_Innovation_Roadmap_250226.pdf

Next Steps

- Included in the June 2025 Public Consultation package (caveat: comments to the Innovation Roadmap will not apply to TYNDP 2026).
- Following the inclusion of the updates suggested in the Consultation, the document will be updated with a view to TYNDP 2028.
- Subject to approval by WGSB, Steering Group, and ENTSO-E SDC and ENSTOG Board, this new version will be published as part of the 2026 Scenarios Package in Q1 2026.

Innovation Roadmap – innovation prioritisation

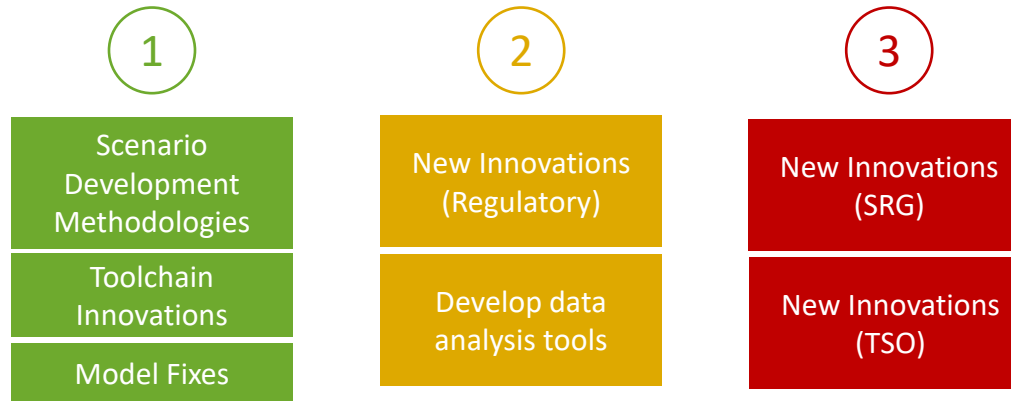

Prioritisation of Innovations for the TYNDP 2026 Planning Cycle

Advancements in Hydrogen Modelling

- Differentiating short-term and seasonal needs for storage and flexibility
- Flow speed in pipelines and cross-border flows,
- Aligning hydrogen import quotas with current numbers
- Hybrid electrolyser production methods to optimize hydrogen pricing.

Enhancing EV Modelling:

- Simulating accurate charging and discharging patterns accurately by 2026
- Grid flexibility.

Other Innovations:

- Methanol modelling for maritime will be explored as a synthetic fuel.

Leveraging Geographic and Climate Data:

- improving climate assumptions in modelling.

Upgrading Scenario Modelling Tools:

- non-EU countries like Norway and Switzerland by 2026, developing web-based interfaces for transparent scenario sharing in data visualization

Innovation Roadmap – model topology

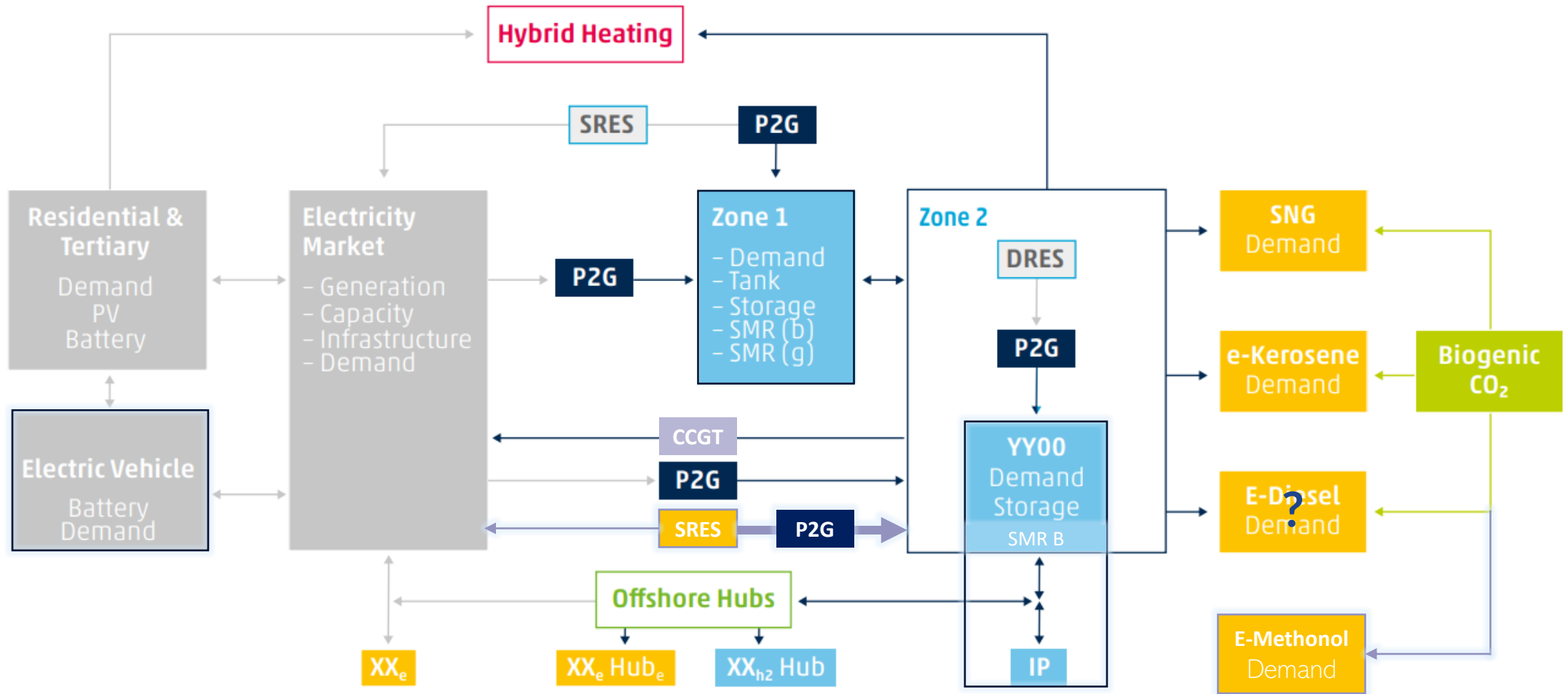

TYNDP 2026

Scenario Building

Collaboration for the 2026 TYNDP cycles

10 minutes

SRRG



STAKEHOLDER REFERENCE GROUP
FOR THE TYNDP SCENARIOS

Andrzej Ceglarz (RGI), Elisabeth Cremona (EMBER)

ENTSO-E and ENTSOG's webinar: TYNDP 2026 Scenarios process update & Innovation Roadmap

6th March 2025

What is the SRG?

Stems from the ACER Scenario Guidelines (Jan 23) “to ensure key stakeholders are appropriately consulted and have the opportunity to interaction among themselves.”

- Formally established in Autumn 2023, following application process
- Co-creation of Terms of Reference (TOR)

Responsibilities

1. Timely, independent, expert input to the ENTSOs’ development of scenarios
 - Scrutiny of inputs, assumptions and modelling methodologies
 - Informed and balanced view, reflecting majority and minority views
2. Co-creation of stakeholder engagement plans (published by the ENTSOs)
3. Evaluation of the scenario-development process and recommendations for improvements of the next cycle

Members and structures of SRG

SRG Members (currently 26 Members)

- EU DSO Entity
- Associations involved in the electricity market
- Associations involved in the gas market
- Heating and cooling stakeholders
- CCS and CCU stakeholders
- Independent aggregators
- Demand-response operators
- Supply-side operators
- Organisations involved in energy efficiency solutions
- Energy consumer org.
- Civil society reps
- Other organisations
- Independent experts

SRG Observers: ENTSOs, EC, ACER, ESABCC

See list: <https://www.entsos-tyndp-scenarios.eu/stakeholder-involvement/>

Organisational set-up

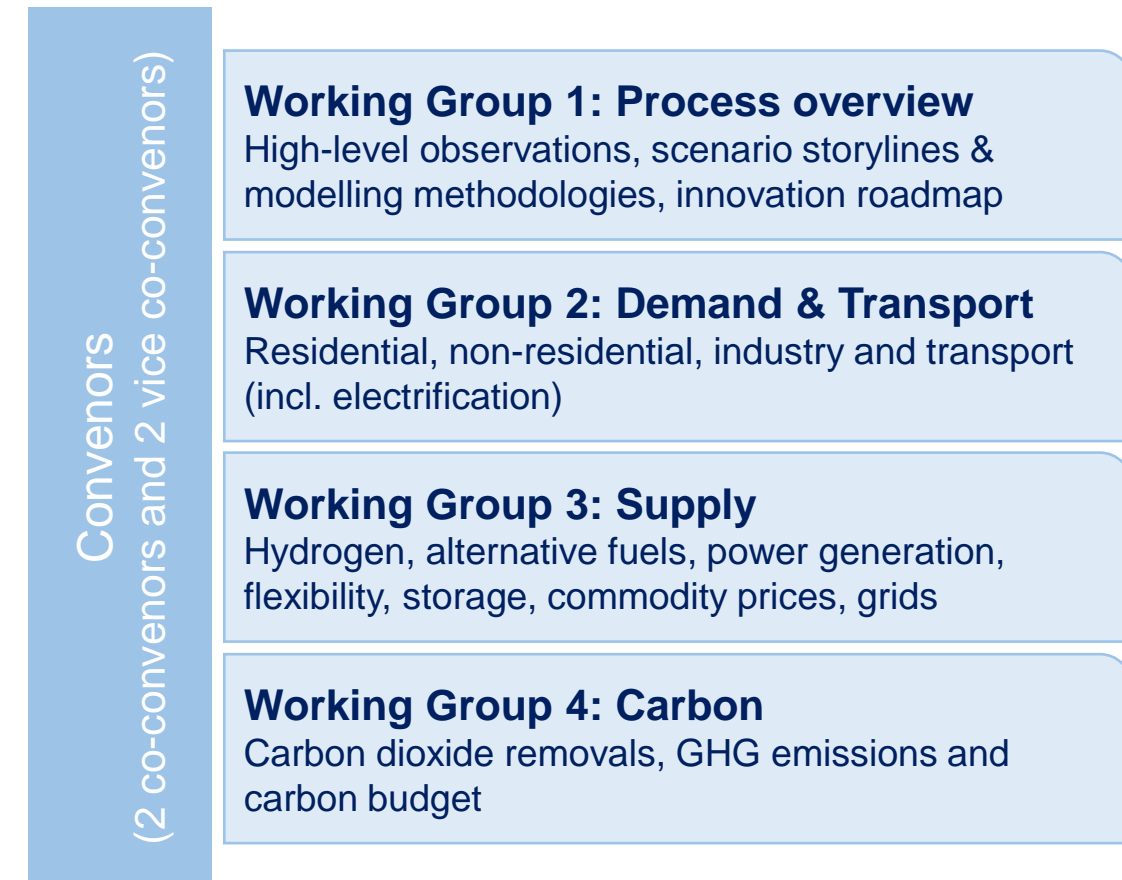

Work of the SRG to date

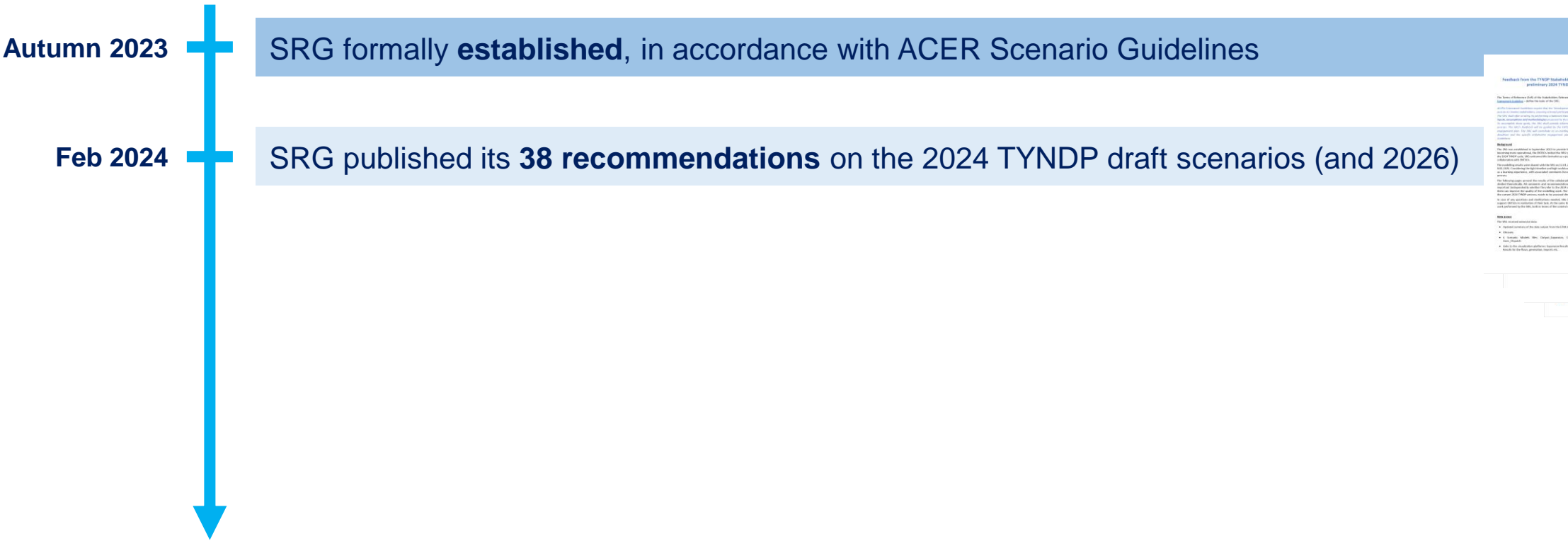

Autumn 2023

SRG formally **established**, in accordance with ACER Scenario Guidelines

Feb 2024

SRG published its **38 recommendations** on the 2024 TYNDP draft scenarios (and 2026)



SRG's first recommendations

On Feb 9th 2024, the SRG delivered 36 recommendations to the ENTSOs building on the preliminary scenario results. 12 recommendations were in regards of the 2024 results.

Nr.	Topic	Number of recommendations
1	Timeline	1
2	Quality of provided files and visualisation	2-5
3	Comparability with European Commission's scenarios and output model	6-7
4	Transparency and availability of modelling assumptions and methodologies	8
5	Accessibility	9
6	Modelling approach	1-12
7	Demand	13-21
8	Hydrogen	22-26
9	Wind energy	27
10	Electricity production	28
11	Demand response	29-30
12	Batteries and EV's	31-32
13	District heating	33-34
14	CO2 supply	35
15	PEMDB (Pan-European Modelling Database)	36

Work of the SRG to date

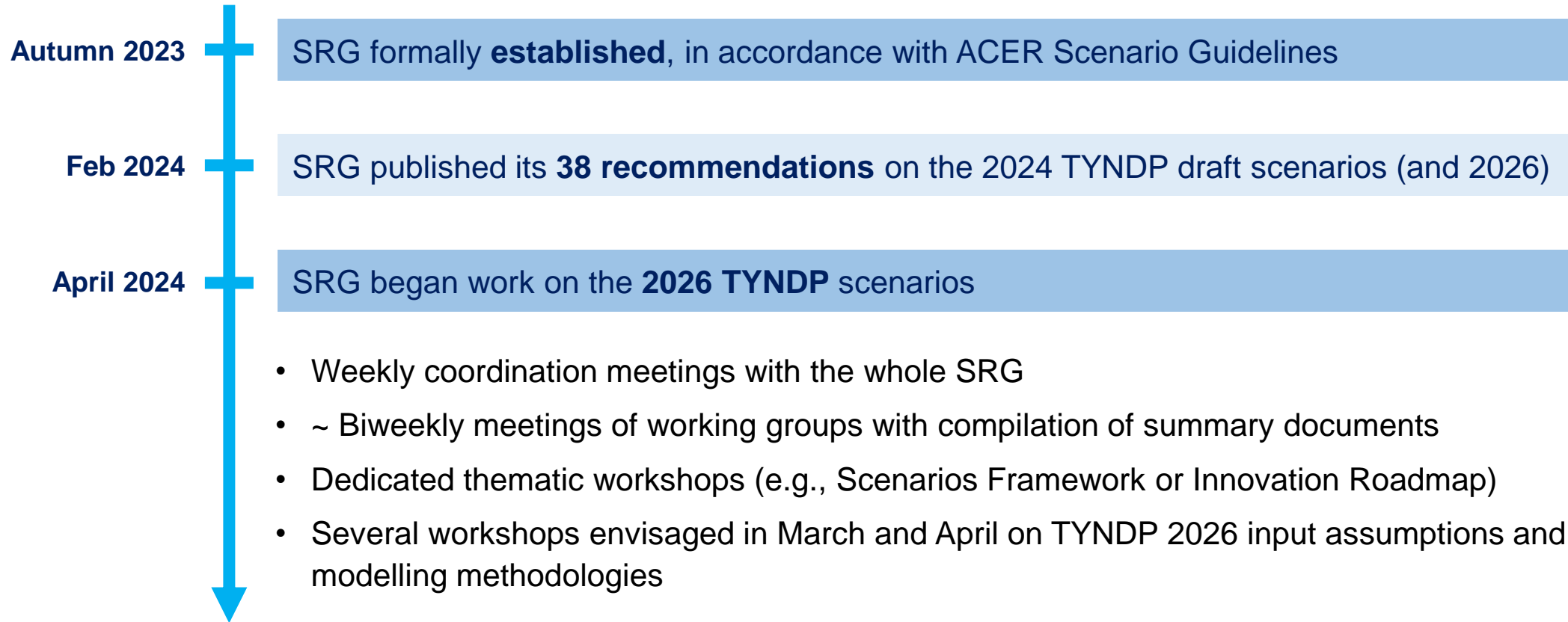

SRG input on 2026 TYNDP so far (1)

Working Group 1: Process overview

- ENTSOs presented different options on how to deal with the economic variants, with subsequent discussions with the SRG (started May 2024)
- SRG feedback on the TYNDP 2026 Stakeholder Engagement Plan
- SRG input to Innovation Roadmap
- Ongoing development of the SRG opinion on the economic variants

Working Group 2: Demand & Transport

- Workshop on EV modelling, with recommendations for improvement (May 2024)
- Workshop on ETM, with suggested data updates and changes (H2 2024)
- Workshop on modelling of demand from heat-pumps, including heating technology shares, COP calculations and load profiles for the demand forecasting tool (February 2025)

SRG input on 2026 TYNDP so far (2)

Working Group 3: Supply

- Data checks on capacities of power generation and flexibility technologies, including modelling methodologies (ongoing)
- Discussions on flexibility of heat pumps (ongoing)
- Discussions on hydrogen – pricing mechanisms, projected fuel costs, flexible operations of electrolysers (ongoing), Hydrogen Production configuration Z1/Z2

Working Group 4: Carbon management

- Discussions on carbon budget methodology for 2026 scenarios (ongoing)

Key takeaways

SRG is a new body within the TYNDP process, which became fully operational and able to fulfil its responsibilities in a relatively short time.



The SRG delivered relevant feedback to the 2024 TYNDP results and actively contributes to the 2026 TYNDP process (written feedback + inputs via multiple exchanges).



Fruitful, intense and constructive collaboration with ENTSOs and with the organisations, that the SRG mandate comes from (ACER & EC).



The SRG functioning proves the importance of transparency, stakeholder scrutiny & input, and participatory approaches within the TYNDP process.

SRG

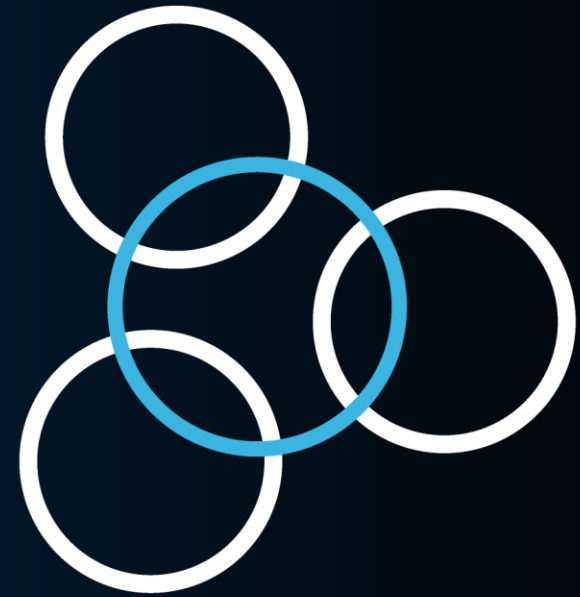

STAKEHOLDER REFERENCE GROUP

Thank you!

TYNDP 2026

Scenario Building

Q&A

Participants can join at [slido.com](https://www.slido.com) with code **#3087824**
30 minutes



TYNDP 2026

Scenario Building

Next Steps & Conclusion

10 minutes

TYNDP 2026 scenarios timeline and engagement opportunities

Scenarios detailed timeline & stakeholder engagement plan and innovation roadmap is available online in 2026.entsos-tyndp-scenarios.eu

! Mark your agendas: public consultation on input parameters and methodologies will start in late May 2025

The consultation package will include:

- Supply & demand inputs (TSO data collection for information)
- Supply & demand assumptions
- Modelling methodologies & draft assumptions
- Draft Gap filling methodologies
- Draft Carbon Budget Methodology
- Draft Supply tool
- Economic variants building methodologies
- Innovation roadmap

Thank you for your attention

Contact information:

www.entsos-tyndp-scenarios.eu
scenarios@entsos-tyndp-scenarios.eu

Location: Brussels

Date: 06.03.2025

